

**Unigate V5  
owner's manual**

LAKE  
PEOPLE

dB ○ 1 ○○ * ○○○ 4 ○○○○ * ○○○○○ 9 ○○○○○○ * ○○○○○○○ 25 ○○○○○○○○ * ○○○○○○○○○ 50		T F I N E R T U N I N G
		F I L T E R
		R A N G E
		A T T E N U A T I O N
		F I L T E R
		M O D E

UNIGATE V5

**LAKE PEOPLE**

**Unigate V5** owner's manual

**Unigate V5  
owner's manual**

© 1989 LAKE PEOPLE

**L A K E P E O P L E**

ROB GARTENSTRASSE 13 - D-7750 KONSTANZ - TELEFON 0 7 5 3 1 / 2 4 4 2 8 - FAX 0 7 5 3 1 / 2 5 9 9 4

# Unigate V5 owner's manual

## THE RACK SR 3

The rack is made of black, varnished sheet steel and fits into conventional 19"-racks, requiring one height unit. Also, it is prepared for free-standing operation. For this purpose, it is equipped with four rubber feet on the underside. The over-dimensioned power supply unit for the modules is integrated into the rack. Mains connection is established via a fixed EURO plug and cable. The mains switch can be found on the right side of the front panel. A LED indicates that the unit is ready for operation. The mains fuse is mounted on the rear wall of the rack, accessible from outside, and may only be replaced by a fuse of the same type. Three module plug-in positions in the rack SR 3 are available. All required connections are made via a mother PC Board inside the rack. The rear wall of the rack accomodates the connection jacks which are assigned to the respective modules.

**Important:** owing to the rack SR 3, the usualy unbalanced outputs of the LAKE PEOPLE modules are electronically balanced. Therefore, it is necessary to use balanced connectors. The negative phase may not be short-circuited against ground.

## INSERTING THE MODULES

Disconnect the unit from the mains! Check all pins of the 31-pin male connector(s) for proper adjustment and make sure that no pin is bent. Insert the module into the desired plug-in position of the rack and push it in without jamming it, until the front panel of the module is flush with the front side of the rack. Tighten the two screws on the left and right of the front panel. Now the module is ready for operation. All connections have been established via the mother board inside the rack.

For dismantling the modules, the same procedure, however, in reversed order, is required. Stereo modules may have additional interconnections. **THEREFORE, MOUNT AND DISMOUNT THESE MODULES AS ONE COMBINATION ONLY.**

## SPECIFICATIONS SR 3

- Dimensions (WxHxD): 435/483 x 44 x 286 mm
- 17.1/19 x 1.7 x11.2 in
- Color: black
- Mains: 100 - 120 / 200 - 240 volts / 18 watts
- Weight: 2.7 kg
- Modules: 3 (max.)
- Connections: 9, phone jack or XLR

# Unigate V5 owner's manual

## THE RACK SR 9

The rack is made of stable and sturdy cast aluminium and fits into conventional 19"-racks, requiring three height units. Also, it is prepared for free-standing operation. For this purpose, the side frames accommodate hinged feet. The front feet may be locked at two different heights and thus also allow inclined set-up of the unit. The over-dimensioned power supply unit for the modules is mounted on the right side of the frame.

Mains connections is established on the rear wall of the rack via the enclosed mains cable with apparatus plug. The corresponding socket integrates the mains fuse which may only be replaced by a fuse of the same type. Two light-emitting diodes (LED) on the front of the power supply indicate that the two operation voltages are available. The rack offers a whole of nine module slots. All necessary connections are made via the mother PC Board inside the rack. The rear side of the mother board accommodates phone jacks which are assigned to the respective plug-in slots.

**Important:** the rack SR 9 meets VDE specifications. Thus, humming problems, due to earth loops may occur. In this case, a common ground point, connected to all shielded racks, will be a suitable countermeasure.

## INSERTING THE MODULES

Disconnect the unit from the mains! Check all pins of the 31-pin male connector(s) for proper adjustment and make sure that no pin is bent. Exactly insert the PC Board of the module to be plugged in into the respective grooves of the upper and lower PC Board guides. Else, the pins might be bent, broken off or the PC Board might be damaged. Now insert the module, until the front panel is flush with the rack. Mount the neck screws on top and bottom and tighten them. Now, the module is ready for operation. All necessary connections have been established via the mother board inside the rack. For dismantling the modules the same procedure, however, in reversed order, is required. Stereo modules may only be mounted and dismantled in combined form.

## SPECIFICATIONS SR 9

- Dimensions (WxHxD): 449/483 x 132 x 266 mm,
- 17.6/19 x 5.1 x 10.4 in
- Color: black, silver
- Mains: 100 - 120 / 200 - 240 volts / 50 watts
- Weight: 3.7 kg
- Modules: 9 (max.)
- Connections: 27 phone jacks

# Unigate V5 owner's manual

## DESCRIPTION

The LAKE PEOPLE UNIGATE V5 is a fully controllable noise gate with a filter applied to the side chain for quicker program material processing. Signal procession is done by a high-quality, fast and low-noise VCA. Consequently, "click" problems or additional noise generation, etc will not occur at all.

The broad-range THRESHOLD, ATTACK and DECAY parameters allow adaption to any program source.

The LED CHAIN constantly indicates the functions of the gate and the attenuation of the input signal.

The tuneable FILTER even allows processing of difficult signals. Extremely short attack times and low threshold levels are possible.

The DUCK function provides further features like level automation and reverse gating efficiently supported by the range control.

## APPLICATION

All parameters of the UNIGATE V5 are variable, so that it offers sufficient flexibility for use in all phases of sound engineering. From recording an individual track to the complete mix-down, it finds application as noise gate or as an all-purpose effects device, thus fostering the user's creativity and eliminating technical problems. For PA operation it guarantees rich sound while the user may control the dynamics without noise, hum and distortions.

## NOISE GATE APPLICATIONS

The UNIGATE V5 solves problems in any multi-track studio. The following forms of noise reduction or noise gating are possible:

- multi-track tape noise
- amplifier noise and/or hum
- increase of crosstalk attenuation
- noise produced by effects devices.
- street noises
- noises produced by fans and air-condition systems
- pedal and keyboard noises
- breath sounds

## EFFECTS APPLICATIONS

The UNIGATE V5 even generates a multitude of effects. A lot of these effects can be created while doing the mix-down.

- accentuation of percussive sounds
- emphasizing background instruments
- stereo simulation
- keying instruments and tracks to each other
- suppressing noise, etc
- automated talkback using the ducking function

# Unigate V5 owner's manual

## THE CONTROLS

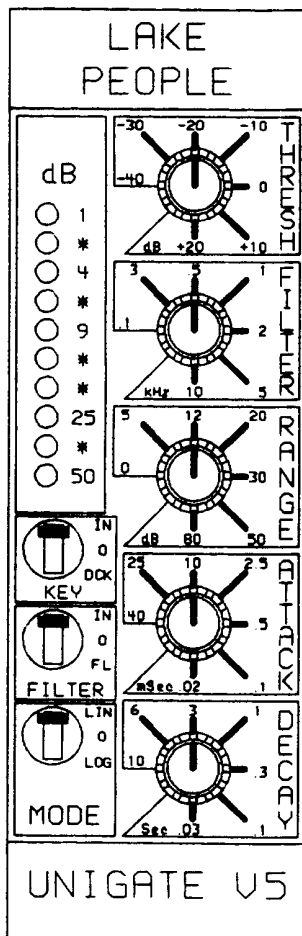

**THRESHOLD:** infinitely variable from +20 to -40 dB for adapting the UNIGATE V5 to the desired signal threshold. Above the threshold the unit acts as an amplifier with a gain factor of 1. Below the threshold signals are processed.

**FILTER:** a 2<sup>nd</sup> order bandpass with a pass-band width of 1/3 octave finds application (Q= 3). The filter is tunable from 100 Hz to 10 kHz.

**RANGE:** for determining the relative attenuation of the signal below the threshold level, for example, a RANGE setting of 30 dB produces a signal attenuation of 30 dB.

**ATTACK:** infinitely variable for adaption of the attack time to the program material.

**DECAY:** infinitely variable for adaption of the decay time to the program material.

**LED CHAIN:** indicates via 10 LEDs and an indication range of 50 dB the current level reduction of the material to be processed.

**KEY:** in position "IN" the key input is activated. In position "0" the signal applied to the input is used for processing. In position "DUCK" the gate's functioning will be reversed, i.e. a KEY signal above the threshold closes the gate. This setting also interchanges attack and decay times.

**FILTER SWITCH :** if the switch is set to position "0", the filter is turned off. In position "IN" the filter is placed before the threshold detector. Now, the bandpass can be tuned with the filter control. In position "FL" = "Filter listen", the filter may be monitored at the output. In this case, the normal output of the gate is muted. The LED chain, however, is still active, so that the gate's functions can be monitored visually.

**MODE:** if the switch is set to position "0", the unit is bypassed. The signal is not processed. In position "LIN" the gate is turned on, the signal is processed with a dB-linear decay characteristic-line, in position "LOG" the signal is processed using a negatively logarithmic decay characteristic-line.

# Unigate V5 owner's manual

## SPECIFICATIONS

INPUT, KEY:	electronically balanced
IMPEDANCE:	20 kohms bal.; 10 kohms unbalanced
MAX. INPUT LEVEL:	> + 21 dBm
FREQUENCY RESPONSE:	20 Hz - 40 kHz +/- 0.5 dB
OUTPUT:	unbalanced
MAX. OUTPUT LEVEL:	> + 21 dBm / $R_L \geq 600$ ohms
DISTORTIONS:	< 0.02%
DYNAMICS:	> 120 dB
S/N (gate open):	> 92 dB / IHF-A: > 100 dB
THRESHOLD:	-40 dB - +20 dB
FILTER:	2 <sup>nd</sup> order band-pass
FILTER RANGE:	100 Hz - 10 kHz
FILTER SLOPE:	12 dB/octave
FILTER WIDTH:	1/3 octave
GAIN REDUCTION:	0 - 80 dB
ATTACK TIME:	0.02 - 40 ms (for 20-dB-signal-increase)
DECAY TIME:	0.03 - 10 s (for 20-dB-signal-decrease)
DISPLAY RANGE:	0 - 50 dB, 10 steps
CONNECTIONS:	31-pin male connector
SUPPLY VOLTAGE:	+/- 18 volts, max. 100 mA
DIMENSIONS (WxHxD):	40 x 129 x 160 mm (1.5 x 5.0 x 6.2 in)

## 31-PIN MALE CONNECTOR

PIN NO.		PIN NO.	
INPUT (+)	: 5	INPUT (-)	: 8
INPUT (GROUND)	: 6/7	OUTPUT	: 10
OUTPUT (GROUND)	: 9/11	KEY (+)	: 25
KEY (-)	: 24	KEY (GROUND)	: 23
VOLTAGE (+18 V)	: 13/19/31	VOLTAGE (-18 V)	: 14/21
VOLTAGE (GROUND)	: 12/18/20/ 29/30		

# Unigate V5 owner's manual

## CONNECTION

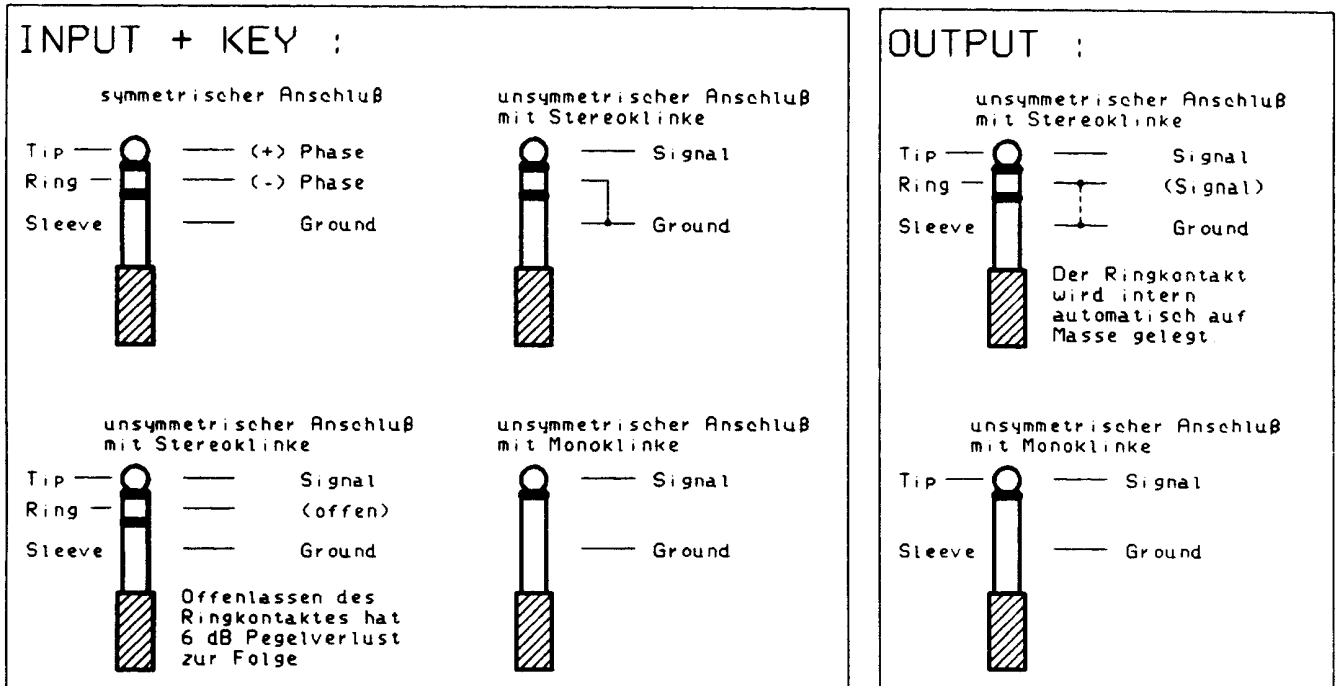

## CONNECTIONS

Connections from and to other units are established on the rear of the module enclosure. The jacks assigned to each UNIGATE V5 are designated IN and OUT and KEY. Connection should be in accordance with the previous diagram for versions with phone jacks. The input is electronically balanced, however, also unbalanced connectors may be used. The output is unbalanced.

## THRESHOLD

With the THRESHOLD control the threshold level of the UNIGATE V5 is adapted to the signal level applied. Signals above the threshold level pass the unit unaffected. The unit works as an amplifier with a gain factor of 1. Signals below the threshold level are processed according to the adjusted parameters, i.e. are gated.

## FILTER (CONTROL)

The filter is a 2<sup>nd</sup> order band-pass which can be tuned with the help of a control, over a range from 100 Hz to 10 kHz. The filter is located at the beginning of the side chain, before the threshold detector. Now, the detector has not to evaluate the entire



frequency range, but only the range 'cut out' by the filter. Thus, setting the threshold is very easy and not crucial, even with extremely demanding program material. In most cases, the threshold can be placed much lower which results in a shortened attack time and optimized characteristics of the forward edge of the material to be processed. Another advantage can be seen in the fact that here the loudest signal has not to be used as trigger reference, as long as the signal with a higher level is at a sufficient distance to the processed signal, with regard to frequency.

The filter may be used independently of the gate. Switch setting "FL" can also be used in the Bypass Mode.

## **RANGE**

The RANGE control determines the minimum level or the maximum level reduction respectively. The range can be varied between 0 and 80 dB level reduction. Often it is desirable to limit the maximum attenuation with the RANGE control to avoid "pumping" or other unwanted effects. In ducking mode, the RANGE control adjusts the attenuation of the signal at the input.

## **ATTACK**

The ATTACK control determines the time constant of the attack control-voltage. It is variable from 0.02 - 40 ms per 20 dB signal increase. The correct attack setting should be found out by way of experiment. Longer attack times result in softer attack characteristics and - to a certain extent - provide adequate protection against unwanted trigger effects due to percussive pulses. In general, percussive signals require shorter attack times, instruments with less percussive character and vocals can be processed easier and more efficiently with longer attack times.

## **DECAY**

The DECAY control determines the time constant of the decay control-voltage. It is variable from 0.03 - 10 sec per 20 dB signal attenuation. The shape of the control voltage can be changed from dB-linear to negatively logarithmic. In position LOG, the control voltage changes slowly first, however, as the curve advances, it decreases more rapidly than the linear one. In position LIN, the control voltage response is dB-linear. The effect of a logarithmic response is similar to a delayed decay and can be used, for example, for quickly decaying program material - to avoid noise - and for low-frequency signals. The correct decay time, as well as the linear or logarithmic response should be found out experimentally. These settings heavily depend on the program material to be processed.

## MODE

- 0: if the MODE switch is set to "0", the UNIGATE V 5 does not process the signal. The unit works as an amplifier with a gain factor of 1; the signal is simply looped through.
- LIN: in position LIN, the signal is processed in accordance with the adjusted parameters. The decay characteristics is db-linear.
- LOG: in position LOG, the signal is processed according to the adjusted parameters. The decay characteristic is negatively logarithmic.

## FILTER (SWITCH)

- 0: if the FILTER switch is set to "0", the filter is not applied to the side chain. The result is a broad-band processing of the signal.
- IN: in position IN, the filter is switched before the side chain. It offers the side chain a certain excerpt of the frequency range the width of which is determined by the filter control. The signals may come from the KEY input or the INPUT.
- FL: in position FL, the filtered signals are routed to the output where they may be checked and monitored. The normal output of the UNIGATE V 5 is muted. The LED chain, however, is still active, so that the functions of the gate can be monitored visually. The signals may come from the KEY input or the INPUT.

Switch setting FL is independent of the remaining settings of the gate (except the setting of the FILTER control). If required, it may also be used individually.

## KEY

- 0: if the KEY switch is set to "0", the key input is not active. The unit obtains the relevant information from the input signal.
- IN: in position IN, the unit obtains the relevant information from the - now activated - key input. A signal applied to the input will be processed by means of the information provided by the key signal.
- DUCK: in the DUCK mode, the functions of the gate are reversed. At the same time, only the key signals will be taken into account for processing the input signal. The unit will now attenuate the input level when the key signal is above the level determined by the THRESHOLD control. The degree of attenuation can be set with the RANGE control. Furthermore, also the attack and decay functions are interchanged. The attack time now influences the sloping edge of the output signal and the decay time influences the forward edge. The LOG-mode of the decay function produces a positively logarithmic response.

## **ADDITIONAL REMARKS**

### **AVOIDING NATURAL REVERB**

When recording with several microphones natural reverb and background sounds produced by other instruments are received by microphones that are currently not in use. Of course, this may be avoided by "gain riding", however, a more elegant, precise and easier way is to gate each single microphone. Higher resolution and better locating depth will be the result.

### **NOISE REDUCTION**

If annoying tape noise is to be eliminated, adjust the THRESHOLD in such a way that the UNIGATE V5 triggers just at the quietest passage occurring. To suppress unwanted additional effect, adjust the remaining parameters accordingly. Thus, perfect signal-to-noise ratios can be achieved.

### **STEREO SIMULATION**

An interesting effect is an artificial stereo signal generated out of a mono source. The mono signal is routed directly to, for instance, the left channel. Adjust ATTACK and DECAY times until they reproduce the original sound. Now, via THRESHOLD it is possible to have the signal peaks reproduced by the right channel - with accentuation; the basic volume can be adjusted with the RANGE control. The room portions and the level with a lower volume remain in the left channel.

### **AUTOMATED TALKBACK FUNCTION**

In DUCK mode, the preamplified speakers signal is applied to the key input. The music signal is present at the input. When the speaker starts talking, the music signal at the output of the gate will be reduced in volume. The degree of level reduction may be adjusted with the RANGE control. Breaks or pauses made by the speaker, may lead to unwanted level changes; these can be removed by slightly prolonged DECAY times (in LOG mode).





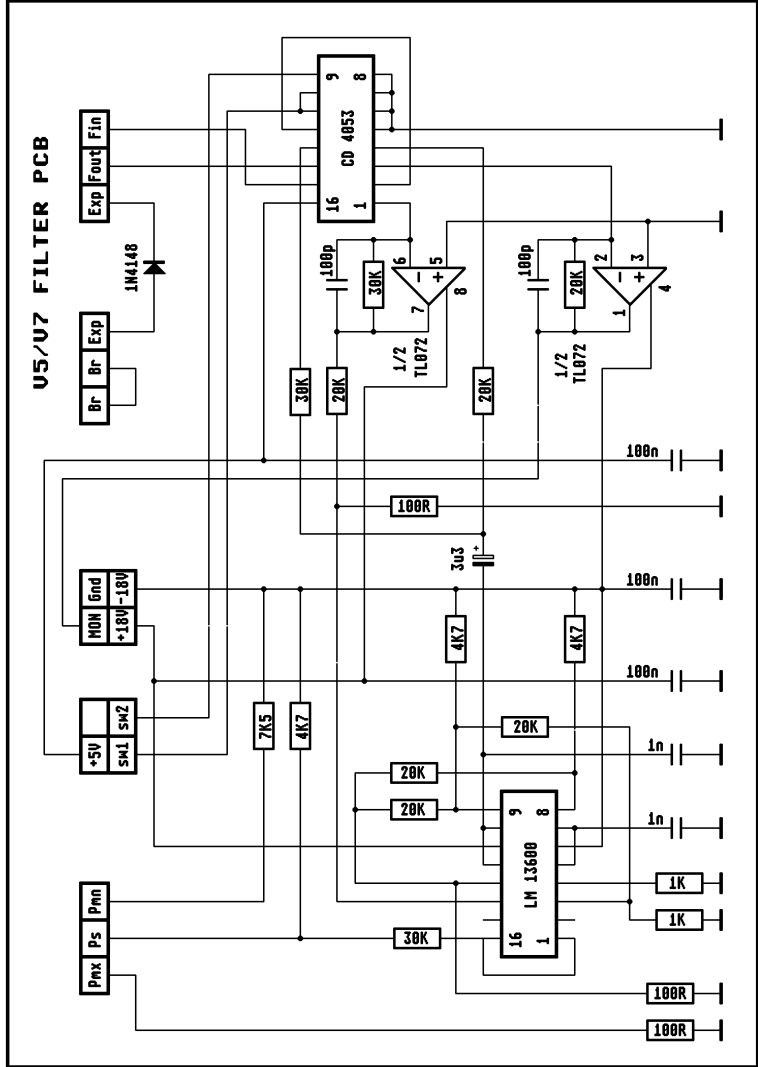

**PART OF MAIN PCB**

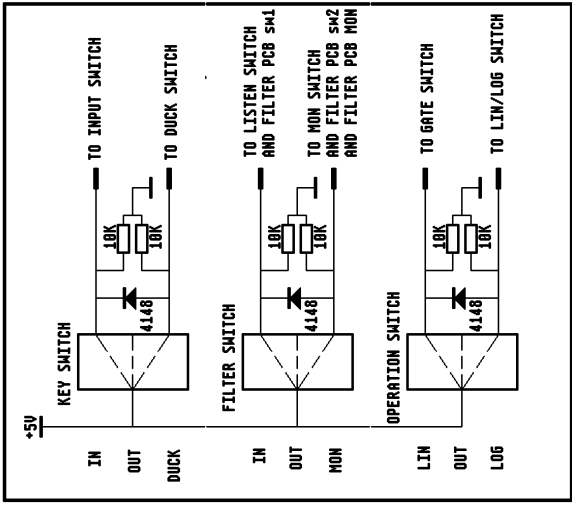

	LAKE PEOPLE		UNIGATE U7	
	D-78467 KONSTANZ		SCHEMATICS	
	DESIGNED BY: F. REIM	VERSION: 3.0	DATE: 05.08.199	
	FILE: UNI U712.PCB		MODIFICATIONS:	
SHEET 2 of 3		4		