



HEADPHONE AMPLIFIER

HPA V181



USER'S MANUAL

Content

Theme	Page
About Vioelectric	3
Safety Instructions	5
The Earth / Grounding Concept	7
Connection / Connectors	9
General	10
Operation	11
Things to know	19
Dismantling / Jumper Settings	26
Disposal	27
Technical Data	30
Conformity Statement	31
Warranty	32

CAUTION !!

**THE HIGH OUTPUT LEVELS ACHIEVABLE
WITH THIS UNIT MAY
DAMAGE YOUR HEARING OR THE HEADPHONES
IF OPERATED CARELESSLY !!**

Cordial thanks for your decision in favour of a

VIOLECTRIC product !

VIOLECTRIC is a trademark and product line of Lake People electronic GmbH. Lake People electronic GmbH develops, manufactures and distributes products in the professional range, for broadcast, television, airports, exhibition halls, festival venues, theatres, large-scale installations, private studios and more. In the private sector as well, Lake People products become increasingly popular due to their outstanding quality.

The **VIOLECTRIC** trademark and product line is specially intended to supply the Hi-Fi and High-End market with its specific requirements.

Who develops **VIOLECTRIC equipment ?**

VIOLECTRIC devices are exclusively developed in Germany by the engineers of Lake People electronic GmbH. In doing so, the team of developers can draw on twenty years of experience and countless products for the pro-audio domain.

Among others, the first German-made 20-bit A/D and D/A converters were developed by Lake People in the early nineties of the past century.

Who manufactures **VIOLECTRIC equipment ?**

VIOLECTRIC devices are exclusively manufactured in Germany by Lake People electronic GmbH or contractors in the company's vicinity.

Lake People - and by association **VIOLECTRIC** - put high emphasis on domestic manufacturing. As well, all component suppliers are chosen in order to achieve the main part of added value inland.

How do **VIOLECTRIC** devices get to the customer ?

VIOLECTRIC devices can be obtained from respective specialist suppliers. If there is none such accessible regionally, the customer is supported by transregional distribution partners (google may help...) and, of course, by Lake People electronic GmbH themselves.

... and if it doesn't work like it should ?

VIOLECTRIC devices are covered by a 24-month warranty. In case of any malfunction during this period, they can be shipped to the manufacturer directly. Of course, the client will benefit from **VIOLECTRIC**'s and Lake People's full technical support even when warranty has expired. Any technical questions or need for advice is welcome.



is a subsidiary of



LAKE PEOPLE

LAKE PEOPLE electronic GmbH
Turmstrasse 7a
D-78467 Konstanz

Fon +49 (0) 7531 73678

Fax +49 (0) 7531 74998

www.vioelectric.de www.vioelectric.com
www.lake-people.de www.lake-people.com

General Safety Instructions

WARNING

For your protection, please read the following:

Water, Liquids, Moisture:

This appliance should not be used near water or other sources of liquids. Care should be taken so that objects do not fall and liquids are not spilled into the enclosure through openings.

Power Sources:

The appliance should be connected to a power supply only of the type described in the operating instructions or as marked on the appliance.

Grounding:

Care should be taken that this appliance is operated with proper grounding only.

Power Cord:

Power supply cords should be routed so that they are not likely to be walked on or pinched by items placed upon or against them, paying particular attention to cords at plugs, convenience receptacles, and the point where they exit from the appliance.

This unit is equipped with a 3-pole mains cable with German 3-pin mains plug. In some countries this unit must be operated with a mains adaptor, supplied by the owner.

Please refer to the table below to connect a mains plug:

OVERVIEW: POWER CORD FUNCTION AND COLORS			
CONDUCTOR		COLOR	Alternativ
L	LIVE	BROWN	BLACK
N	NEUTRAL	BLUE	WHITE
E 	PROTECTIVE EARTH	GREEN+YELLOW	GREEN

U.K. Mains Plug Warning:

A moulded mains plug that has been cut off from the cord is unsafe. Discard the mains plug at a suitable disposal facility.

NEVER UNDER ANY CIRCUMSTANCES SHOULD YOU INSERT A DAMAGED OR CUT MAINS PLUG INTO A 13 AMP POWER SOCKET. Do not use the mains plug without the fuse cover in place. Replacement fuse covers can be obtained from your local retailer. Replacement fuses are 13 amps and MUST be ASTA approved to BS 1362.

Mains Fuse:

The mains fuse of this appliance is soldered in place and accessible from the inside only!!

A blown fuse may indicate an internal problem and should be replaced during qualified servicing or repair work !!

Switchable Power Supply:

Connect this unit to the power source indicated on the equipment rear panel only to ensure safe operation !!

This unit is provided with an internally settable mains supply for 115 / 230 V AC.

Service / Repair:

To reduce the risk of fire or electric shock, the user should not attempt to service the appliance beyond the measures described in the operating manual. All other servicing or repair should be referred to qualified personnel !!

**Electromagnetic Compatibility**

This unit conforms to the Product Specifications noted as **Declaration of Conformity** at the end of this manual. Operation is subject to the following conditions:

- this device may not cause harmful interferences
- this device must accept any interference received, including interference that may cause undesired operation
- this device must not be operated within significant electromagnetic field

The Earth / Grounding Concept

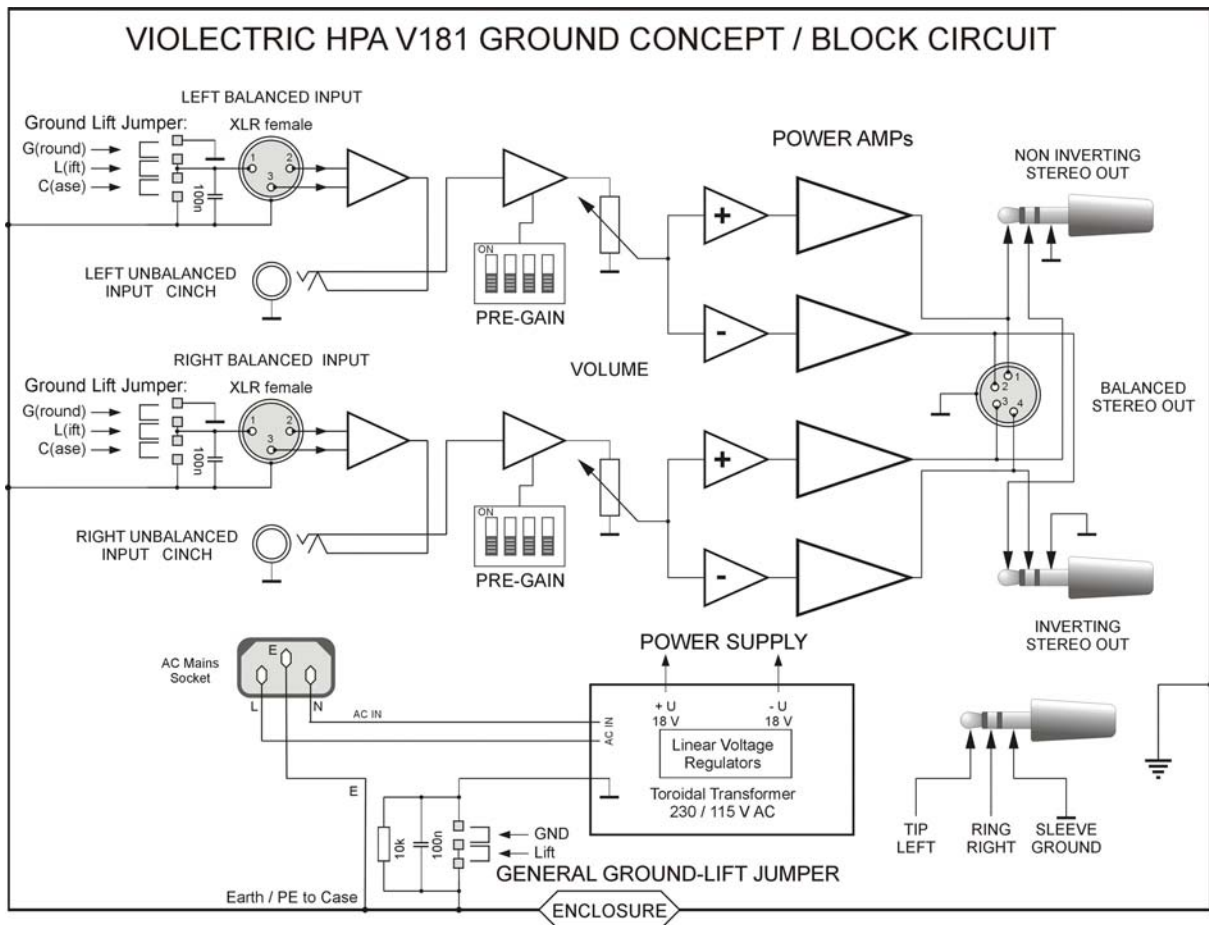

General GROUND-LIFT Jumper (accessible from the inside. Mind the SECURITY INSTRUCTIONS !!):

Ex-works this jumper is set to the **LIFT** position.

The internal ground potential is “lifted” by means of this jumper.

As a result, the interconnection for DC voltages and lower frequencies (< 150 Hz) will be cut. Higher frequencies will be bled off to earth potential through the RC filter. The LIFT position is helpful in case of hum or jitter caused by different ground/earth potentials.

Of course full electrical protection is guaranteed as the case is always connected to ground/earth potential !

See page 28 "Technical Appendix" for details.

Unfortunately there is no general recommendation how to solve hum and jitter problems - or even minimize them. The best way to succeed is to check different options !! In case of balanced cables, it should always been verified if the shield of the cable is connected to the shell of the XLR connector. The shell is ALWAYS connected to earth potential when the connector is inserted !!

Concerning ANALOG inputs and outputs, the relationship between ground and earth may be modified. Electrical safety is always ensured, since the earth conductor is permanently connected to the enclosure !!

XLR GROUD-LIFT Jumper (accessible from the inside.

Mind the SECURITY INSTRUCTIONS !!):

- G(ROUND):** Ex-works all jumpers are set to "**G**" (ground) position.
Pin 1 is connected to the internal ground reference.
High frequency interference is deflected to the case via a 100 nF capacitor.
- L(IFT):** The interconnection between Pin 1 and ground is open.
High frequency interference is deflected to the case via a 100 nF capacitor. This jumper position is specifically useful if the unit is equipped with transformers !!
- C(ASE):** Pin 1 is connected to the case, the 100 nF capacitor is bridged. This jumper position may be varied together with the **General GROUND-LIFT jumper**.

**Please note that with jumpers not in the ex-works position
EMC emission might occur,
for which the user is responsible only !**

Connection / Connectors for Analog and Digital Signals

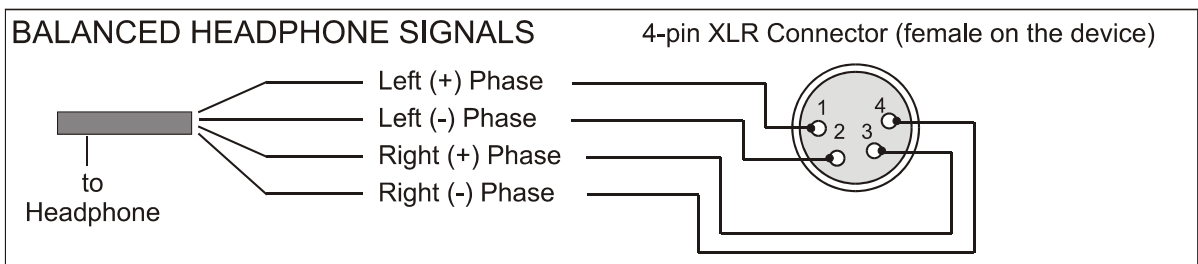
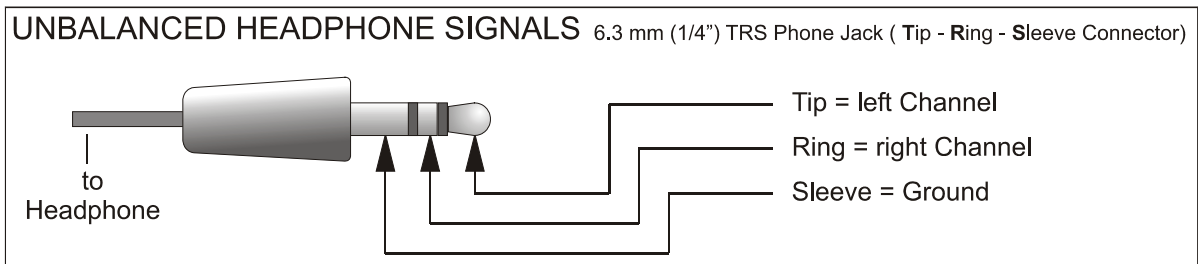
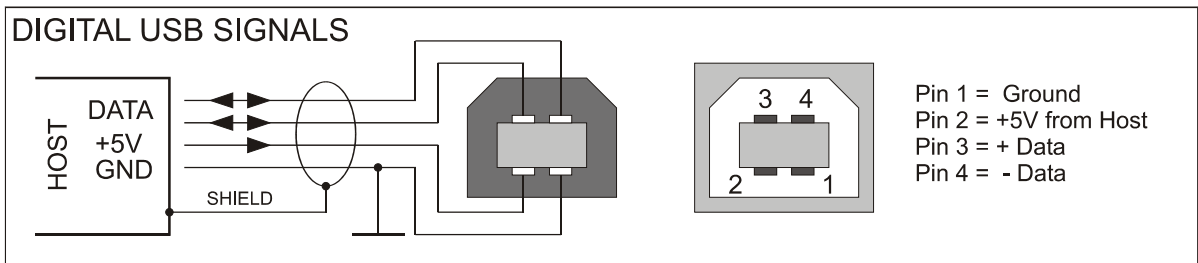
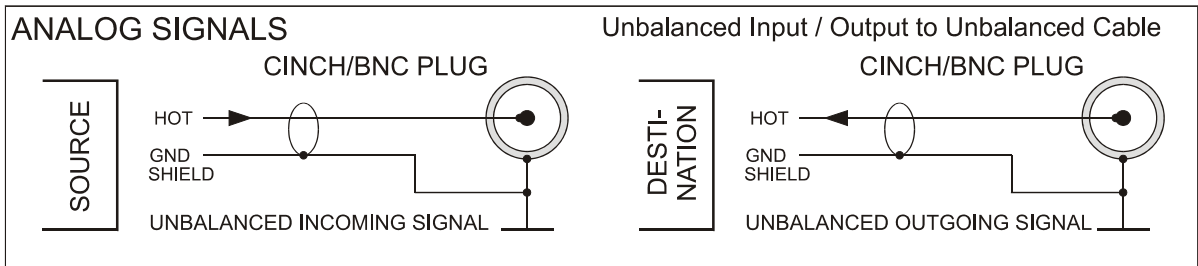
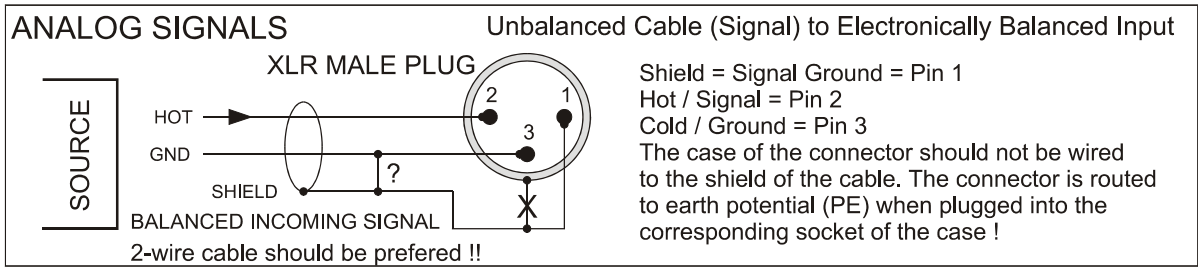
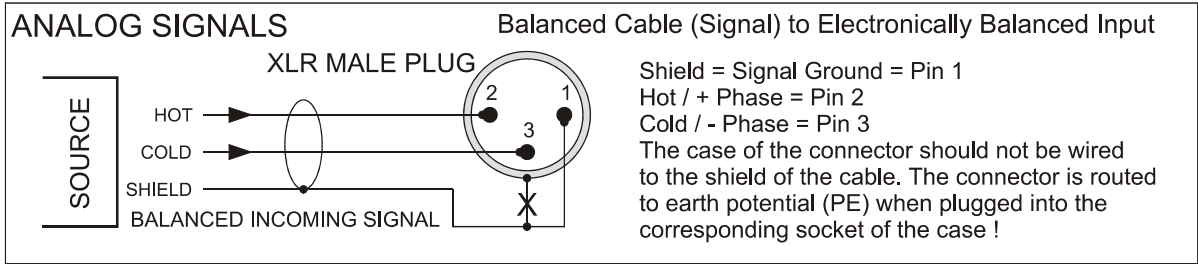

GENERAL INFORMATION

The HPA V181 is a stereophonic headphone amplifier designed to drive low-, medium- and high-Z loads (16...600 ohms) as usually represented by high-quality headphones.

V181 contains four amplifiers (2 x stereo) to enable proper driving of balanced headphones.

Due to its specific, variable and low-noise and distortion circuit design especially optimised for dynamic headphones, the HPA V181 fulfils even highest demands.

Features:

- Balanced inputs with gold-plated Neutrik XLR connectors
- Unbalanced inputs with gold-plated ALPS cinch connectors
- switchable unbalanced outputs with cinch connectors
- Digital input as an option, coaxial, optical, USB, up to 192 kHz
- **PRE-GAIN** = switchable input gain in five steps
- Independent-channel design
- DC-coupled (switchable)
- ALPS RK27 High-Grade volume control
- High-Quality op-amps in the signal path
- High-quality MKP capacitors in the signal path
- 0.1 and 1% metal film resistors throughout the unit
- **4 amplifiers with BUF634**
- 1 balanced headphone output, Neutrik 4-pin, gold plated
- 2 silver-plated Neutrik headphone outputs
- Relay-based headphone output cutoff
- Toroidal transformer
- Large filtering capacitors in the power supply
- Switchable ground lift
- Rugged aluminium case with Nextel coating
- Solid, laser-engraved aluminium front panel

The HPA V181 is equipped with internal filters to prevent damage to the connected headphones due to high-frequency overload beyond the audible range.

THE CASE

The HPA V181's case as well as the front/rear panels are made of solid aluminium. This choice of material ensures high mechanical stability and resistance.

EARTH AND GROUND

The HPA V181's case is grounded. Internal reference ground is bridged to protective earth by means of a jumper. If required, the jumper can be set to 'LIFT' position (**see also: page 7 "Earth/Ground concept", page 28 "Technical Appendix"**).

POWER SUPPLY

Mains power is provided via a three-pin IEC/CEE socket and mating "cold-appliance" mains cord with Schuko-type plug. The device is set to 115 or 230V mains internally, whereas the actual voltage may vary between 190 ... 240 volts (85 ... 120 volts for 115 V operation) for flawless operation. A toroidal transformer provides the internal stabilized operating voltages of +/- 18V .

MAINS FUSE

The 0.25A time-lag fuse is soldered in place on the circuit board. In case, it must be replaced with a fuse of the same type only.

CAUTION !!

MIND THE SAFETY INSTRUCTIONS:

A blown fuse indicates an internal fault and should be replaced during qualified repair or servicing only !!

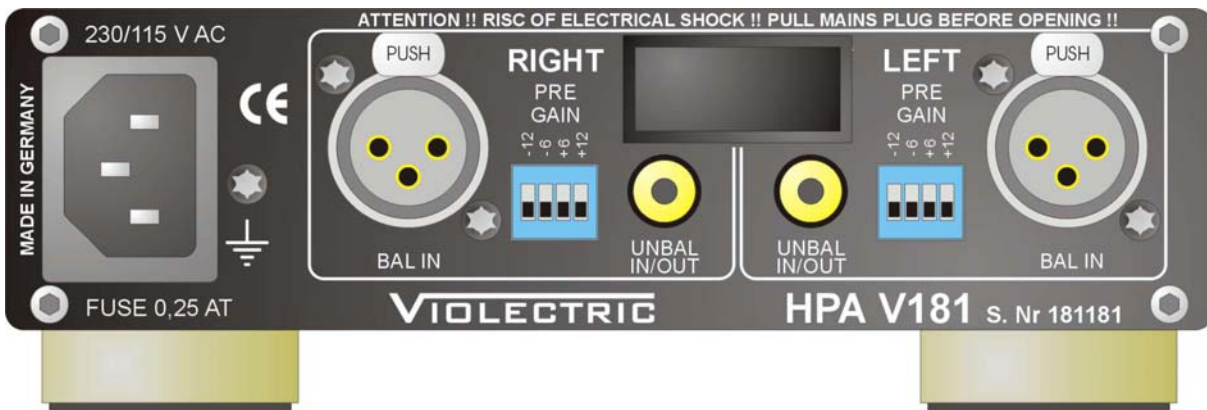

BALANCED SIGNAL INPUTS

The balanced signal inputs are situated on the rear panel of the unit and are labelled as "BAL IN LEFT" and "BAL IN RIGHT". They are fitted with XLR sockets.

Please note:

Unbalanced signals can be injected as well by means of an adaptor.

Also see page 9.

Balanced XLR pinout:	
PIN 1	GND
PIN 2	(+) PHASE
PIN 3	(-) PHASE

UNBALANCED INPUTS

For the use with unbalanced signals, cinch sockets are provided. They are labelled as "IN/OUT LEFT" and "IN/OUT RIGHT", and can be configured as either **inputs** or **outputs**.

(about their configuration, see page 28)

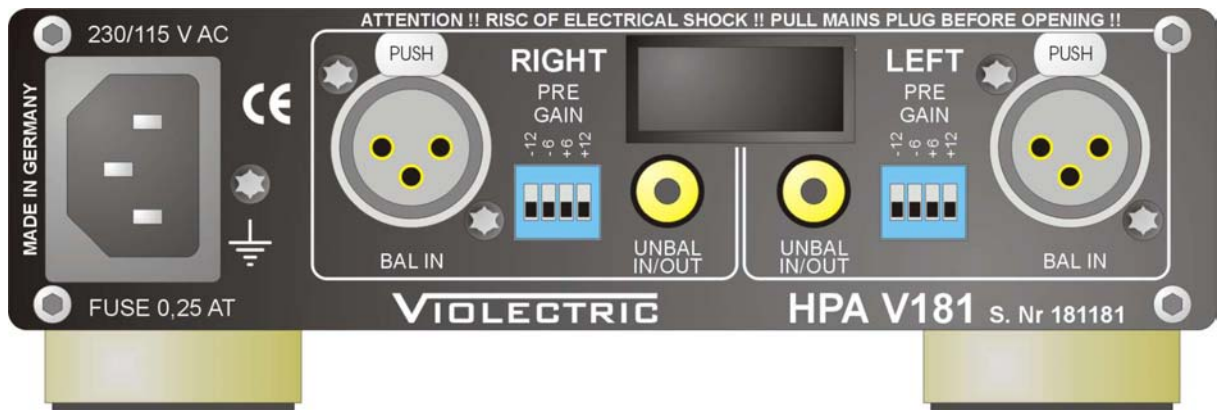

Cinch sockets as inputs:

The cinch sockets are factory-preset as **inputs** and are equipped with integrated switch contacts !

When a cinch plug is inserted, it cuts possible signals applied to the balanced input automatically. I.e. the cinch input has *priority*.

Input impedance for all inputs is 10 kohms.

Maximum input level should not exceed +21 dBu.

This value is reduced to +15/+9 dBu if **PRE-GAIN** is set to +6/+12 dB !!

Cinch socket as outputs:

The cinch sockets can also be operated as **outputs**. This offers the possibility of using a refreshed balanced or USB input signal for further purposes.

Output levels equal the levels applied to the inputs, i.e. the signal is amplified by 0dB (unity gain) at an output impedance of < 30 ohms.

See also page 28 "Technical Appendix"

THE OPTIONAL DIGITAL INPUT

Currently the HPA V181 can be fitted with one out of six D/A converter types, with three different inputs and a max. sample rate of 96 or 192 kHz: The **COAX** input accepts digital PCM audio data in S/P-DIF format, at sample rates from 28 to 108 kHz (or 210 kHz resp.).

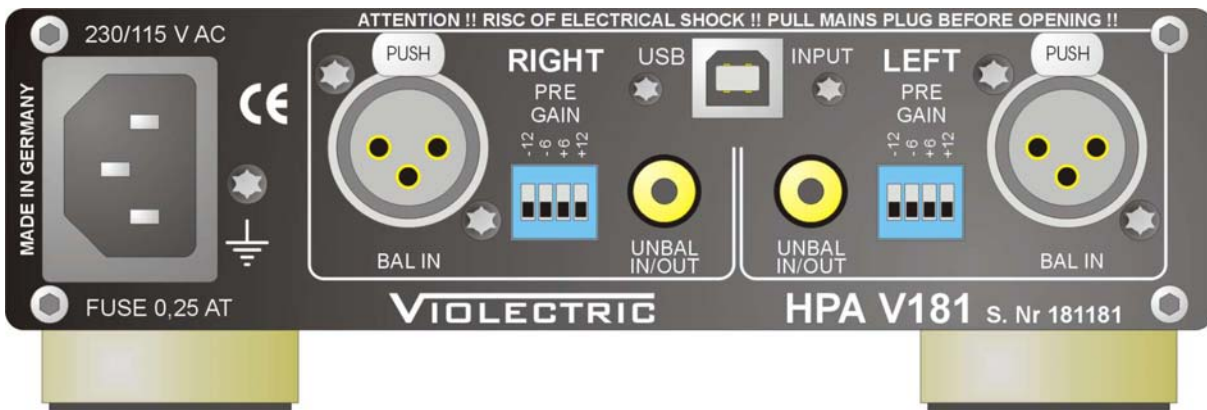

The **OPTO** input, fitted with a TOS-LINK interface, accepts digital audio data at sample rates from 28 to 108 kHz (or 210 kHz resp.).

The **USB** type “B” input can be connected to a host computer (PC or laptop). The USB module will automatically be detected as an audio device.

The **USB 96** input is compatible with USB 1.1 and 2.0 standards. It accepts digital audio formats up to 24 bit at sample rates of 44.1, 48 and 96 kHz, while 88.2 kHz is not supported.

The **USB 192** input is compatible with the USB 2.0 standard. It requires a proprietary driver, which can be downloaded from www.vioelectric.de. Digital audio formats up to 24 bit at sample rates of 44.1, 48, 88.2, 96, 176.4 and 192 kHz are supported, as well as the so-called “asynchronous mode”.

The **96 kHz** digital modules comprise a D/A converter with a dynamic range of 110 dB and –100dB THD+N, thus ranging in the upper-mid performance class.

The **192 kHz** modules are equipped with a top-notch converter offering a 115 dB dynamic range and –103 dB THD+N, along with significantly improved analog output circuitry.

Please note:

- The digital input has priority over all other inputs and will mute these when a valid digital signal is detected
- When a USB cable is inserted, it may be required to restart running media applications on the host.
- Volume control of the host application should be set to 100%.

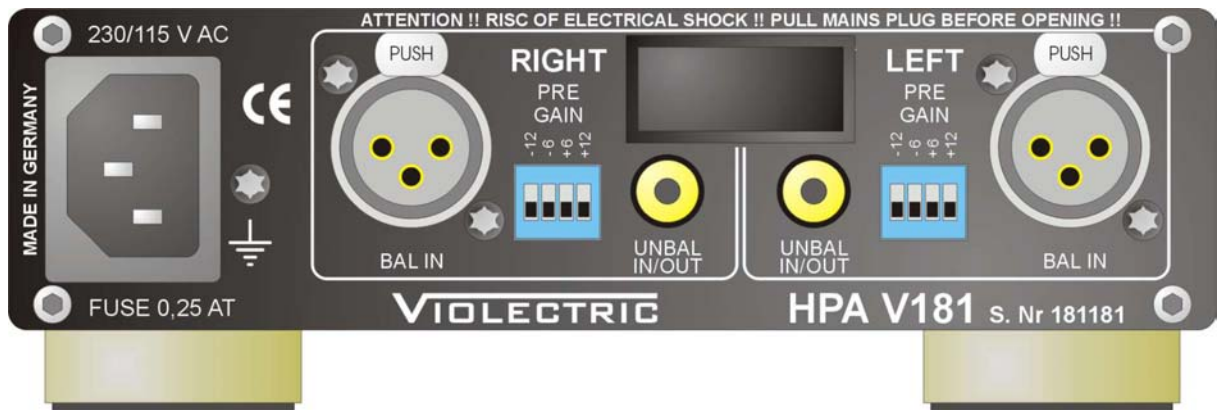

Too loud ? Too soft ? The **PRE-GAIN** method

The V181 is specially designed to drive headphones. Headphones however can present load impedances from 8 to 2000 ohms and efficiency ratios from 85 to 115dB per milliwatt. Thus it can be quite tricky to fulfil all demands, since...

... owners of high-effectivity headphones will rarely set the volume control higher than 9 o'clock in order to exclude hearing damage, while

... the maximum setting may still be too soft for low-efficiency headphones, but

... all users expect highest quality at lowest noise and distortion.

Thus, the *circuitry* must adapt itself as the headphone won't !

WE CALL THE SOLUTION TO THIS PROBLEM **PRE-GAIN**

The alignment between amplifier and headphone is provided by the preamp stage, which can boost or attenuate the input signal in four steps of 6dB each. For this purpose, two switching devices are located on the rear panel for left and right channel individually.

CAUTION !!

The settings should be altered under the following conditions only:

- The unit must be switched OFF
- the "VOLUME" control must be set to minimum
- left and right channel should ALWAYS be set the same
- never increase the setting by more than ONE step per channel at a time.

If you find your HPA V181's volume could be somewhat softer (in order to improve volume control range e.g.), push the switch labelled "-6dB" (half gain) or "-12dB" (quarter gain) in upward direction.

If you find your HPA V181 should provide more gain, do so with the switch labelled "+6 dB" (double gain) or "+12 dB" (quadruple gain).

Ex-factory, all switches are set to their lowest position - i.e. 0 dB or unity gain - which should be sufficient for most applications.



OPERATION

Most control elements and indicators are located on the front panel.

POWER SWITCH

The unit is put into operation by means of the power switch. Power-on status is indicated by the blue LED below.

VOLUME CONTROL

The "VOLUME" control sets the desired output volumes for left and right channel simultaneously.

THE AMPLIFIERS The input signals are fed to a special stereo amplifier which is equipped with 2 power stages per channel to generate balanced signals. It has been designed for this application exclusively.



The individual-channel design provides optimum crosstalk rejection. The amplifier's frequency range stretches from DC to over 200kHz (-3dB cutoff frequency) in order to obtain absolutely linear characteristics within the audible range. Overall gain is set to +8 dB in order to provide sufficient reserves also for high-impedance headphones.

THE BALANCED HEADPHONE OUTPUT

The HPA V181 offers a balanced headphone output. This is equipped with a gold plated female 4-pin XLR connector.

Balanced Headphone socket pinout:	
Pin 1	(+) Left channel
Pin 2	(-) Left channel
Pin 3	(+) Right channel
Pin 4	(-) Right channel

THE UNBALANCED HEADPHONE OUTPUTS

The HPA V181 offers two stereophonic headphone outputs, each equipped with a 1/4" (6.3mm) jack socket.

Unbalanced Headphone socket pinout:	
TIP	Left channel
RING	Right channel
SLEEVE	GND

Please note: the RIGHT phone jack is connected to the in-phase stereo signal, whereas the left phone jack is connected to the 180⁰ phase shifted signal.

On power-up and power-down, the outputs are cut from the amplifier circuitry by relay.

ALTERNATIVE BALANCED HEADPHONE CONNECTION

The phone jacks sockets of HPA V181 may be configured by means of internal jumpers to provide balanced operation with two phone jack. To configure the the sockets please refer to page 29 technical Appendix".

Left phone jack socket		Right phone jack socket	
TIP	(-) left channel	TIP	(-) right channel
RING	(+) left channel	RING	(+) right channel
SLEEVE	Ground (not necessary)	SLEEVE	Ground (not necessary)

HINTS FOR THE BALANCED OPERATION OF HEADPHONES

As there is no common standard about how to make the connectors of balanced headphones and headphone amplifiers, we decided to equip our unit(s) with 4-pin XLR connectors.

In contrary to most XLR standards the female socket is situated on the amp.

If you are not familiar in altering your headphones with matching connectors we offer this work as a service. Please ask !!

ATTENTION:

Your headphone is double as loud as normal in balanced mode !!!

Things to know ...

Why makes it sense to make such huge efforts ?

A headphone amplifier is a device designed to condition audio signals with regard to the very specific requirements of headphones. This doesn't sound too spectacular at the first glance and can be achieved relatively easily. As with many things however, the devil is in the details and much more effort is required to design **one** amplifier for **all** current headphone models.

Headphones per se are quite diverse, and there are two essential parameters: impedance and sensitivity.

In general, headphones with higher impedance can be regarded as less sensitive than headphones with low impedance (which is not generally true, but in the majority of cases). The sensitivity of headphones is usually stated in dB (sound pressure level) per Milliwatt.

Extremes in this sense are the AKG K1000 with 74dB/mW on the one hand, and the Sennheiser HD25 with 108 dB/mW on the other hand: The K1000 requires 2500 times the power to achieve the same sound pressure as the HD25.

There is also the fact that headphones with high impedance usually require much higher voltage to achieve high loudness. Thus the amplifier *must* be designed with high internal supply voltages.

Which advantages do balanced signals offer ?

In contrast to unbalanced signals, balanced signals are carried by two wires (plus ground/shield). In the transmitting device, a balanced signal is created by generating an inverted original signal (180° phase shifted). The "hot" wire carries the original signal (a), the "cold" wire the inverted signal (-a). In the receiving device, the balanced signal is processed by a differential amplifier, which detects the difference between both:

$$(a) - (-a) = 2a.$$

On its way between devices, the useful signal can be affected by interference = (s). Interferences however are in phase on both wires and fed to the differential amplifier as well. Again, the amplifier detects the

difference between the interference contents: $(s) - (s) = 0$. Thus - in an ideal situation - all interference on the signal path is eliminated.

Why are discrete signal paths important ?

Twin op-amps are the most common design for operational amplifiers, i.e. two amplifier circuits are integrated in one device. If left- and right-channel signals are processed simultaneously by such a device, interaction between both cannot be excluded. This interaction is admittedly diminutive, but should be avoided whenever a different design offers the possibility.

Why are op-amps ideal for low-level signal processing ?

Discrete amplifiers (designed with transistors) are very popular in high-end audio design also for preamplifier stages. This is often marketed as an optimization measure, but the partially exorbitant extra expenses are of course to be paid by the customer. But an op-amp consists of transistors as well...

Moreover, its structure has the advantage of thermal coupling between its internal components. Also ageing issues play a much less important role. Due to the large number of op-amps types offered, it is possible to pick an optimum type for any specific application.

Why does PRE-GAIN make sense ?

Two extreme examples (with the HPA V181 at 8dB gain, volume control set to full cw):

1st example:

The (pre-)amplifier provides 4V output voltage, whereas the headphone requires only 2V for 100dB sound pressure level.

With the control fully turned up, the V181 would deliver 10V output at 8dB gain. Therefore the volume control would have to be operated very carefully in order to avoid hearing damage. Moreover, any interference at the input should be avoided since it would be "unforgivingly" amplified as well. With PRE-GAIN, the input level can be reduced by 12dB (a

fourth), with 1V instead of 4V as the result. This 1V is again amplified by 2.5, then equalling 2.5V. Now the volume control can be turned over almost the entire range.

2nd example::

The (pre-)amplifier provides 1V, whereas the headphone requires 20V to release 100dB of sound pressure.

With the volume control fully clockwise, the V181 would provide 2.5V at 8dB gain only - much too low for the headphone. By means of PRE-GAIN, input level can be boosted by 12dB (four times), resulting in effective 4V. These are again multiplied by 2.5, now equalling 10V. This is still not enough, but far closer to the optimum value: The headphone achieves 114dB sound pressure level.

Why does frequency bandwidth limiting make sense ?

In signal processing, sound is represented by AC voltages. Sound is audible - for young people - from about 20 to 20000 Hz. The older the listener, the less he will hear high frequencies in particular.

In order to transmit these frequencies at optimum quality, the frequency response of an amplifier should be as wide and as "flat" as possible. At the low end of the scale, this limit is represented by DC, as there is no frequency lower than zero. In upward direction, the limit can be set to practically any frequency, but the higher, the more susceptible the device becomes concerning electro-magnetic interference. This is not audible in the first place, but may interfere with the useful signal and then become evident. Therefore, unrestricted frequency response attests thoughtlessness rather than remarkable engineering skill.

Why is a good volume pot essential ?

A volume potentiometer is a mechanical control element, which can be obtained on the market at any low price. Meanwhile it is often replaced by electronic circuitry, exhibiting essential disadvantages concerning dynamic range, noise and distortion.

Conductive-plastic resistive tracks, high-quality multi-tap wipers and separated chambers for the individual sections are highly desirable for sophisticated applications, and high quality is inevitable to ensure trouble-free operation for years. Since the market for really good pots is a small one, manufacturers like Noble or Panasonic don't offer these any more. A current sample of top of the line pots is the RK27 by ALPS, which is also used in your HPA V181.

Why is a low output impedance essential ?

When actuated, electro-dynamic systems respond with a counterforce. When the voice coil of a headphone has been displaced by the signal, an (error-) current will be induced when it swings back to its initial position. This current must be suppressed as far as possible, which is effected best if the amplifier's output impedance is the lowest possible. The damping factor describes nothing but the ratio between output impedance of an amplifier and a given load.

Since there is no known technical specification, we define the load (voice coil impedance) as 50 ohms. With V181 having an output impedance of <0.2 ohms this results in a damping factor 250.

Why are high supply voltages essential ?

A headphone doesn't really require high power, but from the equation $P = U^2 / R$ we can see that the square of the supply voltage determines the power into a given load resistance. The higher the headphone's impedance, the more voltage will be needed. But this deals with the achievable loudness to a limited extent only: Technically spoken, music lives on fast transients which put high demands on signal processing. And thus a fast transient can easily push an average amplifier with +/-15 volts supply to its limits (90 % of all headphone amps in the market are operated with these or even lower supply voltages). Due to the high supply voltage of V181 you will benefit from more than doubled output voltage swing capability.

Why does a relay make sense when switching power ?

Amplifiers generate unwanted output signals when applying or removing power, which can damage the connected headphones. The relay breaks the connection between amplifier and headphone and thus protects the latter until electrical conditions have stabilized.

Some words about the different digital input options.

At the moment there are 6 different digital inputs for the V181. These offer coaxial, optical or USB inputs and accept up to 24 bit digital data.

Coax & Opto 96 accept sample rates up to 110 kHz, the USB 96 accepts 44.1, 48 and 96 kHz, please note: NO 88.2 kHz. The USB 96 input is compatible to the USB 1.1 and 2.0 standard.

All the above modules own a D/A converter which we would judge to be “upper middle class” with a dynamic range of 110 dB and THD+N at -100 dB.

Coax & Opto 192 accept sample rates up to 210 kHz, the USB 192 accepts 44.1, 48, 88.2, 96, 176.4 and 192 kHz and supports the so called “asynchronous mode”.

The USB 192 input is compatible with the USB 2.0 standard. It requires a proprietary driver, which can be downloaded from www.vioelectric.de.

The above modules are equipped with a top notch D/A converter with a dynamic range of 115 dB and THD+N at -103 dB, along with significantly improved analog output circuitry.

Which USB devices can be connected to the HPA V181 ?

Connections can be established to table-top or laptop PCs. MP3 players or similar gear cannot be connected.

Why does 100% host volume setting make sense ?

Volume control within the host is always accomplished digitally, i.e. bits are removed from the data stream. This may affect the signal quality because the resolution will become lower and the distortions may rise. In practise those effects will appear at such low levels which will not allow a valuation of the signal quality

DISMANTLING / JUMPER SETTINGS

Hint:

Here we are talking about internal adjustments inside your HPA V181.
You are in need of two screw drivers TORX style size T8 and T10.

You should by all means

PULL THE MAINS PLUG !!!

Only thereafter the settings can be altered without any hazard.

DISMANTLING

As the 4-pin XLR socket is fixed to the back side of the front panel,
the front panel may NOT be disassembled !!

To avoid damages please follow the instruction below:

1. screw off both upper screws on the front panel
2. screw off both upper screws on the back panel.
3. unscrew ALL remaining screws on the back panel by 1/10 " (2-3 mm)
4. now lift the upper lid
5. make your personal jumper settings
5. assemble the unit in reverse order

Frequency bandwidth limiting

Your HPA V181's upper frequency limit is 200 kHz - the so-called "3-dB point" - at which signal level drops by 3dB. This limit is high enough to exclude any effect on the audible spectrum on the one hand, but low enough to provide sufficient rejection of possible radio-frequency interference.

Towards the low end, your HPA V181's frequency response is not restricted at all. This means that even extremely low frequencies - right down to DC - will be amplified. "DC-coupling" as this technique is called, is not necessarily useful since neither DC nor very low frequencies are audible, but may damage your headphones on the other hand.

Therefore, the HPA V181 offers a low-frequency limiting option as well. For this purpose, the two "LO-CUT" jumpers to the left and right of the "VOLUME" control can be swapped from "DC" to "AC" position. When set to "AC", low frequency response is limited to 12Hz, again referred to the "3-dB point".

See also: technical appendix, page 28.

Ex-works, the HPA V181 is set to "AC" response (12Hz).

DISPOSAL



Disposal of Old Electrical & Electronic Equipment
(Applicable in the European Union and other
European countries with separate collection systems)

This symbol on the product or on its packaging
indicates that this product shall not be treated as
household waste. Instead it shall be handed over to
the applicable collection point for the recycling of



electrical and electronic equipment.



By ensuring this product is disposed of correctly, you will help prevent potential negative consequences for the environment and human health, which could otherwise be caused by inappropriate waste handling of this product.

The recycling of materials will help to conserve natural resources.



For more detailed information about recycling of this product, please contact your local Civic Office, your household waste disposal service or the shop where you purchased the product.

JUMPER SETTING HPA V181

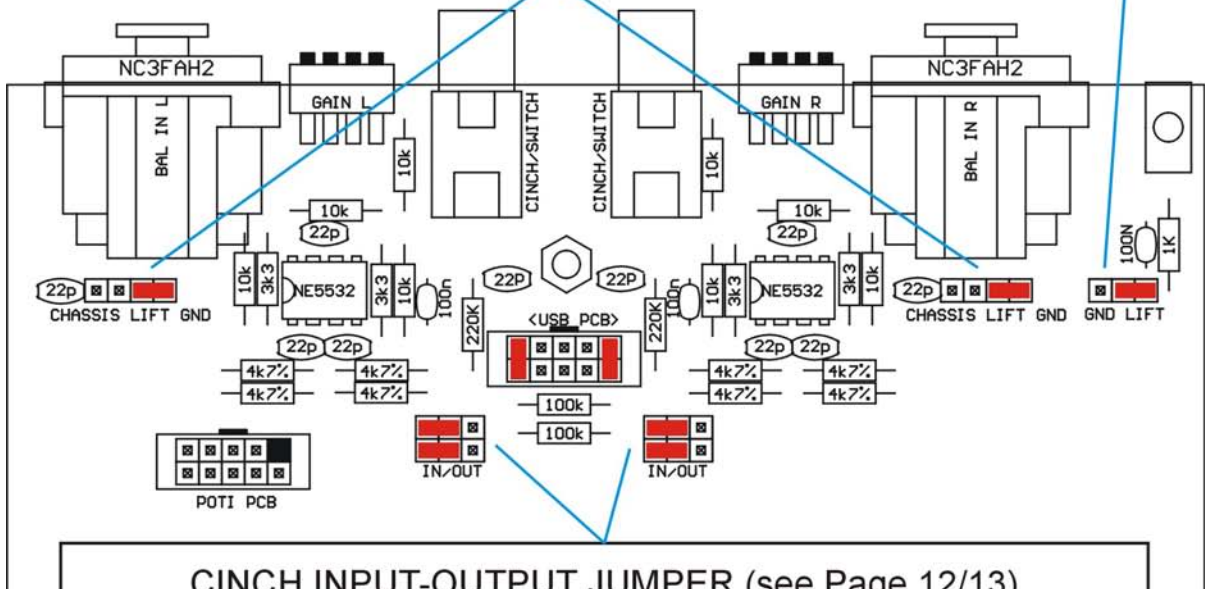

CASE GROUND-LIFT JUMPER (see Page 7)	
 LIFT POSITION (ex works)	 GROUND POSITION

XLR GROUND-LIFT JUMPERs (see Page 8)		
 CHASSIS POSITION	 LIFT POSITION	 GROUND POSITION (ex works)

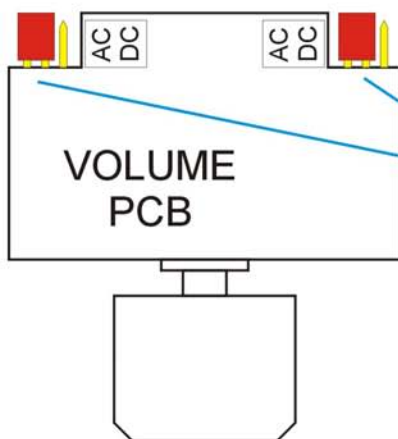

CINCH INPUT-OUTPUT JUMPER (see Page 12/13)	
 INPUT POSITION (ex works)	 OUTPUT POSITION



LO-CUT JUMPER (see Page 17)	
 AC POSITION / 12 Hz (ex works)	
 DC POSITION / 0 Hz	

ALTERNATIVE BALANCED HEADPHONE CONNECTION

Both phone jack sockets of HPA V181 situated left and right from the balanced connector are configured to match “normal” unbalanced jacks ex works. (see page 17)

By means of internal jumpers these sockets may provide balanced operation with two phone jack.

(see page 18 for the right phone jack connection)

After opening the case, the 1/4” sockets may be configured:

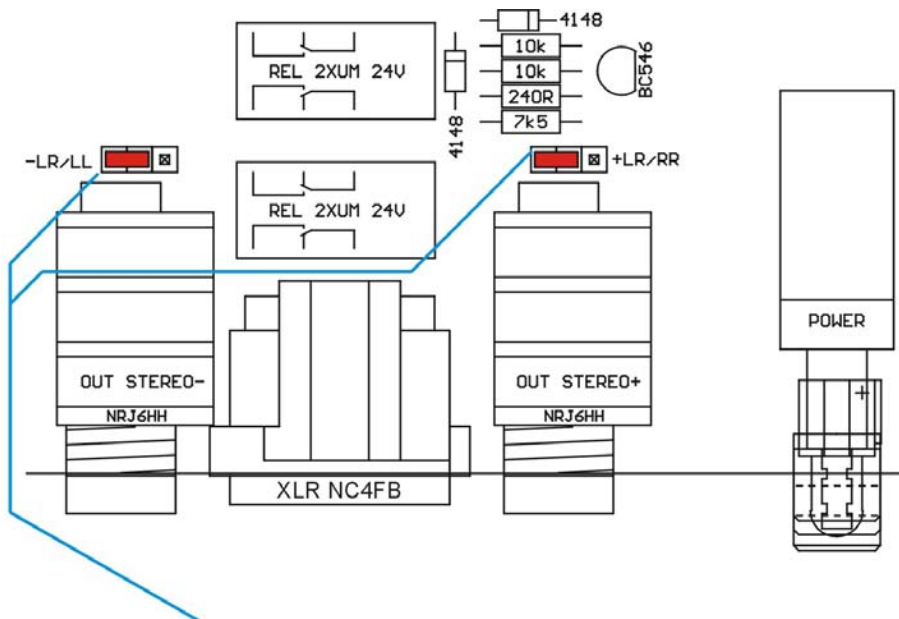

PHONE-JACK OUTPUT CONFIGURE JUMPERs (see Page 18)			
Standard ex Works (unbal. Mode)		Balanced Mode	
-LR / LL 	+LR / RR 	-LR / LL 	+LR / RR
Left socket carries the phase-inverted stereo signal.	Right socket carries the in-phase stereo signal.	Left socket carries the left balanced stereo signal.	Right socket carries the right balanced stereo signal.

ATTENTION:
Jumpers may only be configured simultaneously !!

TECHNICAL DATA HPA V181

All Measurements RMS unwtld., 20 Hz - 20 kHz, Pre-Gain set to 0 dB, Highpass active

Inputs:	2 x XLR female, balanced, 2 x Cinch, unbalanced 1 x USB Style B (optional)
Max. Input Voltage:	+ 21 dBu
Input Impedance:	10 kohms
Buffered Outputs:	2 x Cinch unbalanced
Nominal Input Sensitivity:	+6 dBu
Amplifier Overall Gain:	+8 dB
Overall Gain with PRE-GAIN :	-4 / +2 / +8 / +14 / +20 dB
Frequency Range:	0 Hz ... 55 kHz (- 0,5 dB) 0 Hz ... 200 kHz (-3 dB)
Damping Factor:	> 250 into a Load of 50 Ohms
Dynamic Range:	> 128 dB (A-wtd)
Noise:	< -100 dBu (A-wtd)
THD+N (1kHz/2x10V/100R = 1W)	< -108 dB / < 0,0004 %
THD+N (1kHz/2x4V/32R = 0,5W)	< -109 dB / < 0.00035 %
Crosstalk:	-115 dB (1 kHz) / -100 dB (15 kHz)
Headphone Outputs:	1 x 4-pin XLR, female 2 x ¼" (6.3 mm) TRS Jack

Max. Output Level:
(1kHz / < 0.1% THD+N)

R _L (x 2)	U _a (dBu)	U _a (V)	P _a (mW)
600	28,3	20,2	680
100	26,6	16,6	2700
50	22,4	10,2	2100
32	20,2	7,9	1950
16	15,3	4,5	1250

Supply Voltage:	230 V AC / 115 VAC max. 10 VA
Case, Front, Back:	Aluminium
Dimensions:	170 x 49 x 226 mm (W x H x D)

EC CONFORMITY STATEMENT:

We herewith declare that the following unit

Name: **VIOLECTRIC HPA V181**

Serial No. : -all -

is in conformity with the following EC directives:

2006/95/EG	Low voltage directive
20014/30/EC	EMC directive
EN 60065:2002+A12:2011	Security directives for audio-, video- und similar electronic devices
JIS C6065:2013	
2001/95/EC	General Product Safety Directive

For verification of conformity with regard to electromagnetic compatibility the following harmonized standards are applied:

EN 50081-1:1992	Generic emission standard
EN 50082-1:1992	Generic immunity standard

Product family standard for audio, video, audio-visual entertainment apparatus:

EN 55013:2001	EN 61000-3-2:2000
EN 55020:2002	EN 61000-3-3:1995

2011/65/EU, RoHS directive

2012/19/EU, WEEE directive / Member No.: DE 26076388

This declaration is given under responsibility of:



LAKE PEOPLE *electronic GmbH*
Turmstrasse 7a
D-78467 Konstanz
Fon +49 (0) 7531 73678
Fax +49 (0) 7531 74998



Konstanz 26.09.2014 Fried Reim CEO

WARRENTY

Since 1986 we are constructing and manufacturing sophisticated electronics for ambitious customers.

Since the early beginnings we are trying hard by accompanying measures, the use of 1st choice components and multiple quality checks during production to avoid faults at large.

We are quiet effective in that and this is – amongst others - why we enjoy such a good reputation.

Despite all accurateness faults may occure which may derogate the proper operation of your product.

In this case your unit is protected by a **5-year Warranty !**

Needless to say that we will care for your product even after the expiration of the warranty. If it is necessary please dispatch your item to:

Lake People electronic GmbH
Turmstrasse 7a
D-78467 Konstanz

Fon +49 (0) 7531 73678
Fax +49 (0) 7531 74998
E-Mail info@lake-people.de

Your warranty claim begins with the date of purchase, which should be denoted on your proof of purchase.

Do not forget to include the receipt of sales or a copy of the receipt.

Please also include a short description of the fault(s).

For the reshipment we need you correct address !!

Care for a safe packaging. Best is to use the original packaging.

Please keep in mind that we cannot accept collect freight.

We will grant a quick repair and quick return of the unit.

In case of a warranty repair we will reship free of charge.

Please denote here the serial number and the date of purchase:

Serial Number

Date of Purchase

Additional gear from 

HEADPHONE AMPLIFIERS:

HPA V90

HPA V100

HPA V181

HPA V200

HPA V220

HPA V281

D/A CONVERTER:

DAC V800

PHONO PRE-AMPLIFIER:

PPA V600

LINE PRE-AMPLIFIER:

PRE V630